

EASTMAN PERFORMANCE FILMS, LLC TEST REPORT

SCOPE OF WORK

ASTM E1886 AND ASTM E1996 TESTING ON DR15 SR PS9 FILM, FIXED WINDOW

REPORT NUMBER

J3550.01-109-44

TEST DATE(S)

06/17/19 - 06/18/19

ISSUE DATE

06/28/19

RECORD RETENTION END DATE

06/18/23

PAGES

16

DOCUMENT CONTROL NUMBER

ATI 00498 (07/23/17)

RT-R-AMER-Test-2806

© 2017 INTERTEK

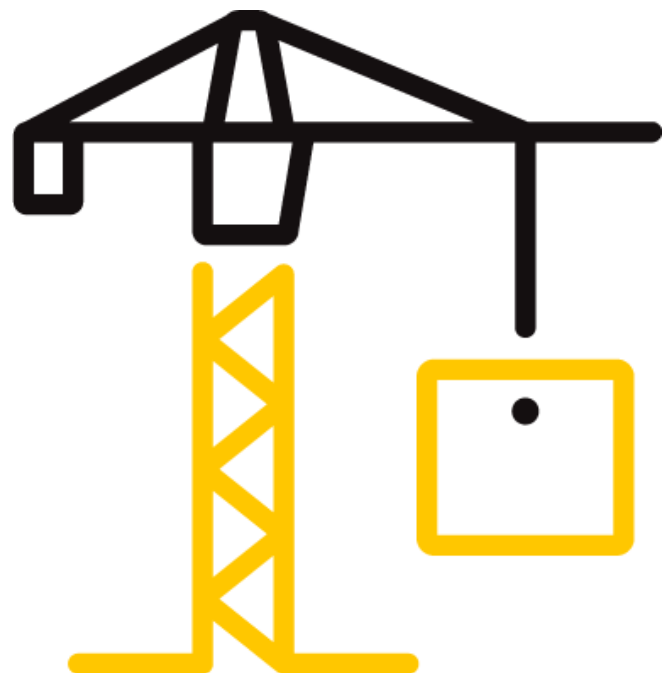

TEST REPORT FOR EASTMAN PERFORMANCE FILMS, LLC

Report No.: J3550.01-109-44

Date: 06/28/19

REPORT ISSUED TO

EASTMAN PERFORMANCE FILMS, LLC

4210 The Great Road
Fieldale, Virginia 24089

SECTION 1

SCOPE

Intertek Building & Construction (B&C) was contracted by Eastman Performance Films, LLC to perform testing in accordance with ASTM E1886 and ASTM E1996 on their DR15 SR PS9 Film, fixed window. Results obtained are tested values and were secured by using the designated test method(s). Testing was conducted at Intertek B&C test facility in York, Pennsylvania.

This report does not constitute certification of this product nor an opinion or endorsement by this laboratory.

For INTERTEK B&C:

COMPLETED BY:	Andrew P. Mehalick
TITLE:	Technician – Product Testing
SIGNATURE:	
DATE:	06/28/19

REVIEWED BY:	Timothy J. McGill
TITLE:	Manager – Product Testing
SIGNATURE:	
DATE:	06/28/19

APM:wnl

This report is for the exclusive use of Intertek's Client and is provided pursuant to the agreement between Intertek and its Client. Intertek's responsibility and liability are limited to the terms and conditions of the agreement. Intertek assumes no liability to any party, other than to the Client in accordance with the agreement, for any loss, expense or damage occasioned by the use of this report. Only the Client is authorized to permit copying or distribution of this report and then only in its entirety. Any use of the Intertek name or one of its marks for the sale or advertisement of the tested material, product or service must first be approved in writing by Intertek. The observations and test results in this report are relevant only to the sample(s) tested. This report by itself does not imply that the material, product, or service is or has ever been under an Intertek certification program.

TEST REPORT FOR EASTMAN PERFORMANCE FILMS, LLC

Report No.: J3550.01-109-44

Date: 06/28/19

SECTION 2

TEST METHOD(S)

The specimens were evaluated in accordance with the following:

ASTM E1886-13a, *Standard Test Method for Performance of Exterior Windows, Curtain Walls, Doors, and Impact Protective Systems Impacted by Missile(s) and Exposed to Cyclic Pressure Differentials*

ASTM E1996-17, *Standard Specification for Performance of Exterior Windows, Curtain Walls, Doors, and Impact Protective Systems Impacted by Windborne Debris in Hurricanes*

SECTION 3

MATERIAL SOURCE/INSTALLATION

Test specimens were provided by the client. Representative samples of the test specimen(s) will be retained by Intertek B&C for a minimum of four years from the test completion date.

The specimens were installed into Spruce-Pine-Fir wood bucks. The rough opening allowed for no shim space. The exterior perimeters of the windows were sealed with duct tape.

LOCATION	ANCHOR DESCRIPTION	ANCHOR LOCATION
Head, sill, and jambs	1" x 1" wood blindstops at the interior of the specimen with #8 x 3" flat head screws	The anchors were located at the head, sill, and jambs. The screws were located 3" from each corner and spaced 8" on center.
	2x4 wood blindstops at the exterior of the specimen with #8 x 3" flat head screws	The anchors were located at the head, sill, and jambs. Two screws were located at each end of the head and sill blindstops and then one screw was spaced 8" on center. The jamb blindstops had one screw at each end and then spaced 8" on center.

Tape and film were not used to seal against air leakage during structural testing.

TEST REPORT FOR EASTMAN PERFORMANCE FILMS, LLC

Report No.: J3550.01-109-44

Date: 06/28/19

SECTION 4 EQUIPMENT

Cannon: Constructed from steel piping utilizing compressed air to propel the missile

Missile: 2x4 Southern Pine

Timing Device: Electronic Beam Type

Cycling Mechanism: Computer controlled centrifugal blower with electronic pressure measuring device

SECTION 5 LIST OF OFFICIAL OBSERVERS

NAME	COMPANY
Steve DeBusk	Eastman Performance Films, LLC
John A. Shanabrook	Intertek B&C
Timothy J. McGill	Intertek B&C
Andrew P. Mehalick	Intertek B&C

SECTION 6 TEST SPECIMEN DESCRIPTION

Product Type: Fixed window

Series/Model: DR15 SR PS9

Product Size(s):

Test Specimens #1 - #3

OVERALL AREA:	WIDTH		HEIGHT	
	millimeters	inches	millimeters	inches
2.2 m ² (24.0 ft ²)				
Overall size	1219	48	1829	72

The following descriptions apply to all specimens.

TEST REPORT FOR EASTMAN PERFORMANCE FILMS, LLC

Report No.: J3550.01-109-44

Date: 06/28/19

Frame Construction:

FRAME MEMBER	MATERIAL	DESCRIPTION
Head, sill, and jambs	Aluminum	Extruded, thermally improved, poured and debridged

	JOINERY TYPE	DETAIL
All corners	Butted	The corners were secured together using two #12 x 1" pan head screws through the head and sill and into the jamb screw bosses. Silicone was used to seal the gap at the glazing pocket.

Reinforcement: No reinforcement was utilized.

Weatherstripping: No weatherstripping was utilized.

Glazing: *No conclusions of any kind regarding the adequacy or inadequacy of the glass in any glazed test specimen(s) can be made.*

GLASS TYPE	SPACER TYPE	INTERIOR LITE	EXTERIOR LITE	GLAZING METHOD
1" IG	Desiccant-filled aluminum spacer	1/4" clear annealed glass with a 0.009" laminate layer on the interior	1/4" clear annealed glass	Exterior glazed against a bead of Dow Corning 995 structural silicone and secured in place using a snap-in aluminum glazing bead at the sill with a rubber glazing strip against the glazing. A rubber glazing wedge was used at the exterior of the head, sill, and jambs.

LOCATION	QUANTITY	DAYLIGHT OPENING		GLASS BITE
		millimeters	inches	
Fixed daylight opening	1	1080 x 1695	42-1/2 x 66-3/4	3/8"

Drainage: No drainage was utilized.

Hardware: No hardware was utilized.

TEST REPORT FOR EASTMAN PERFORMANCE FILMS, LLC

Report No.: J3550.01-109-44

Date: 06/28/19

SECTION 7

TEST RESULTS

The temperature during testing was 27°C (80°F). The results are tabulated as follows:

ASTM E1886, LARGE MISSILE IMPACT

Conditioning Temperature: 27°C (80°F)

Missile Weight: 2132 g (4.70 lbs)

Missile Length: 1.2 m (4' 1")

Muzzle Distance from Test Specimen: 3.7 m (12' 0")

Test Specimen #1: Orientation within ±5° of horizontal

IMPACT	#1
MISSILE VELOCITY	12.1 m/s (39.8 fps)
IMPACT AREA	Lower left corner of daylight opening
OBSERVATIONS	Missile hit target area, broke sacrificial and interior lites, no further damage observed
RESULTS	Pass

Test Specimen #2: Orientation within ±5° of horizontal

IMPACT	#1
MISSILE VELOCITY	12.3 m/s (40.3 fps)
IMPACT AREA	Center of daylight opening
OBSERVATIONS	Missile hit target area, fractured sacrificial and interior lites, no missile penetration
RESULTS	Pass

Test Specimen #3: Orientation within ±5° of horizontal

IMPACT	#1
MISSILE VELOCITY	12.3 m/s (40.3 fps)
IMPACT AREA	Top right corner of daylight opening
OBSERVATIONS	Missile hit target area, missile fractured sacrificial and interior lites, tore laminate 2" long in L-Shape at impact location, no further damage
RESULTS	Pass

Note: See Intertek B&C Sketch #1 for impact locations.

TEST REPORT FOR EASTMAN PERFORMANCE FILMS, LLC

Report No.: J3550.01-109-44

Date: 06/28/19

ASTM E1886, AIR PRESSURE CYCLING

Test Specimen #1:

Design Pressure: ±2394 Pa (±50.0 psf)

Positive Pressure

PRESSURE RANGE Pa (psf)	NUMBER OF CYCLES	AVERAGE CYCLE TIME (seconds)	OBSERVATIONS
479 to 1197 (10.0 to 25.0)	3500	2.36	Fractured interior lite, some delamination of laminate from glazing, no further damage
0 to 1436 (0 to 30.0)	300	3.53	No change observed
1197 to 1915 (25.0 to 40.0)	600	2.73	No change observed
718 to 2394 (15.0 to 50.0)	100	3.70	No change observed

Negative Pressure

PRESSURE RANGE Pa (psf)	NUMBER OF CYCLES	AVERAGE CYCLE TIME (seconds)	OBSERVATIONS
718 to 2394 (15.0 to 50.0)	50	3.59	Fractured interior lite, some delamination of laminate from glazing, no further damage
1197 to 1915 (25.0 to 40.0)	1050	2.53	No change observed
0 to 1436 (0 to 30.0)	50	3.43	No change observed
479 to 1197 (10.0 to 25.0)	3350	2.47	No change observed

Result: Pass

TEST REPORT FOR EASTMAN PERFORMANCE FILMS, LLC

Report No.: J3550.01-109-44

Date: 06/28/19

ASTM E1886, AIR PRESSURE CYCLING

Test Specimen #2:

Design Pressure: ±2394 Pa (±50.0 psf)

Positive Pressure

PRESSURE RANGE Pa (psf)	NUMBER OF CYCLES	AVERAGE CYCLE TIME (seconds)	OBSERVATIONS
479 to 1197 (10.0 to 25.0)	3500	2.36	Fractured interior lite, some delamination of laminate from glazing, no further damage
0 to 1436 (0 to 30.0)	300	3.53	No change observed
1197 to 1915 (25.0 to 40.0)	600	2.73	No change observed
718 to 2394 (15.0 to 50.0)	100	3.70	No change observed

Negative Pressure

PRESSURE RANGE Pa (psf)	NUMBER OF CYCLES	AVERAGE CYCLE TIME (seconds)	OBSERVATIONS
718 to 2394 (15.0 to 50.0)	50	3.59	Fractured interior lite, some delamination of laminate from glazing, no further damage
1197 to 1915 (25.0 to 40.0)	1050	2.53	No change observed
0 to 1436 (0 to 30.0)	50	3.43	No change observed
479 to 1197 (10.0 to 25.0)	3350	2.47	No change observed

Result: Pass

TEST REPORT FOR EASTMAN PERFORMANCE FILMS, LLC

Report No.: J3550.01-109-44

Date: 06/28/19

ASTM E1886, AIR PRESSURE CYCLING

Test Specimen #3:

Design Pressure: ±2394 Pa (±50.0 psf)

Positive Pressure

PRESSURE RANGE Pa (psf)	NUMBER OF CYCLES	AVERAGE CYCLE TIME (seconds)	OBSERVATIONS
479 to 1197 (10.0 to 25.0)	3500	2.36	Fractured interior lite, some delamination of laminate from glazing, no further damage
0 to 1436 (0 to 30.0)	300	3.53	No change observed
1197 to 1915 (25.0 to 40.0)	600	2.73	No change observed
718 to 2394 (15.0 to 50.0)	100	3.70	No change observed

Negative Pressure

PRESSURE RANGE Pa (psf)	NUMBER OF CYCLES	AVERAGE CYCLE TIME (seconds)	OBSERVATIONS
718 to 2394 (15.0 to 50.0)	50	3.59	Fractured interior lite, some delamination of laminate from glazing, no further damage
1197 to 1915 (25.0 to 40.0)	1050	2.53	No change observed
0 to 1436 (0 to 30.0)	50	3.43	No change observed
479 to 1197 (10.0 to 25.0)	3350	2.47	No change observed

Result: Pass

**SECTION 8
CONCLUSION**

The specimen(s) tested met the performance requirements set forth in the referenced test procedures for a ±2394 Pa (±50.0 psf) Design Pressure with missile impacts corresponding to Missile Level C. The specimens met the requirements of Section 7 of ASTM E1996.

TEST REPORT FOR EASTMAN PERFORMANCE FILMS, LLC

Report No.: J3550.01-109-44

Date: 06/28/19

SECTION 9 SKETCH

REV	DATE	DESCRIPTION	BY

TEST SPECIMEN #1

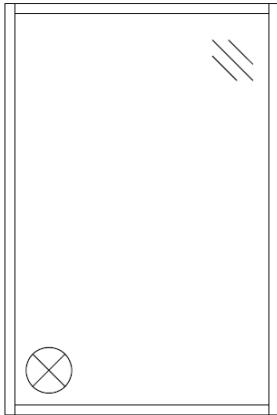

TEST SPECIMEN #2

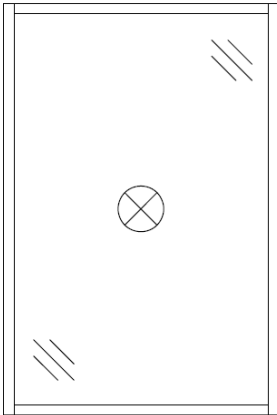

TEST SPECIMEN #3

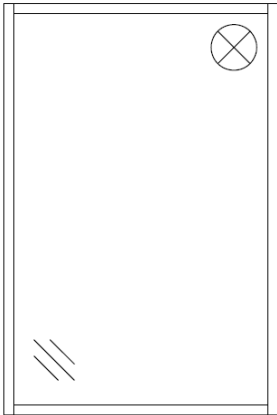

IMPACT LOCATIONS

PROJECT NO. J3550.01 109 - 44	PROJECT NAME: DR15 SR P59 FILM ASTM E1886/E1996 EVALUATION CLIENT: EASTMAN PERFORMANCE FILMS, LLC	 <small>Total Quality. Assured.</small>	DRAWING SKETCH #1 IMPACT LOCATIONS	DWG. BY: EMB DATE: 6/27/19	SHEET 1 OF 1
-------------------------------------	---	---	---------------------------------------	-------------------------------------	-----------------------

SKETCH #1 IMPACT LOCATIONS

TEST REPORT FOR EASTMAN PERFORMANCE FILMS, LLC

Report No.: J3550.01-109-44

Date: 06/28/19

SECTION 10 PHOTOGRAPH



Photo No. 1
Test Specimen #2 Prior to Testing



Total Quality. Assured.

130 Derry Court
York, Pennsylvania 17406

Telephone: 717-764-7700
Facsimile: 717-764-4129
www.intertek.com/building

TEST REPORT FOR EASTMAN PERFORMANCE FILMS, LLC

Report No.: J3550.01-109-44

Date: 06/28/19

SECTION 11 DRAWINGS

The test specimen drawings have been reviewed by Intertek B&C and are representative of the test specimen(s) reported herein. Test specimen construction was verified by Intertek B&C per the drawings included in this report. Any deviations are documented herein or on the drawings.

Eastman Performance Films, LLC
Intertek Quote 210800R0 Windstorm Testing
Test Sample Details

intertek Total Quality. Assured.	Report #:	J3550.01-109-44
	Date:	6/21/2019
	Verified by:	<i>Andrew P. Mehalak</i>

Kawneer 450 Aluminum Framing

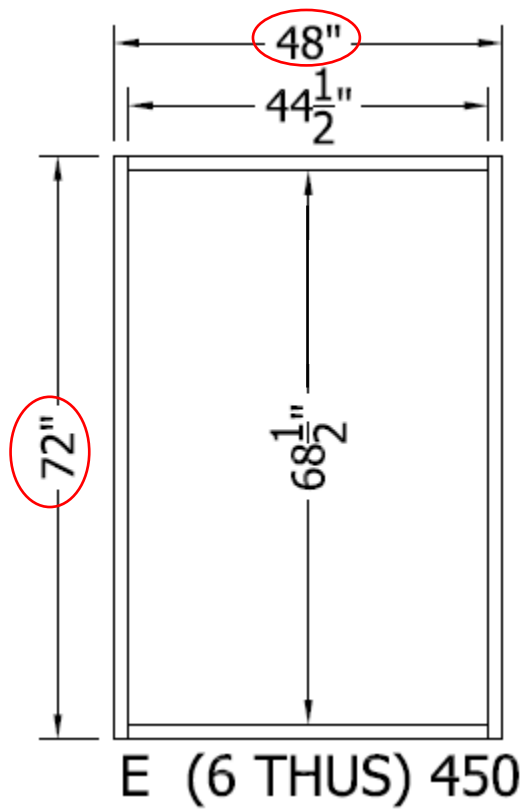

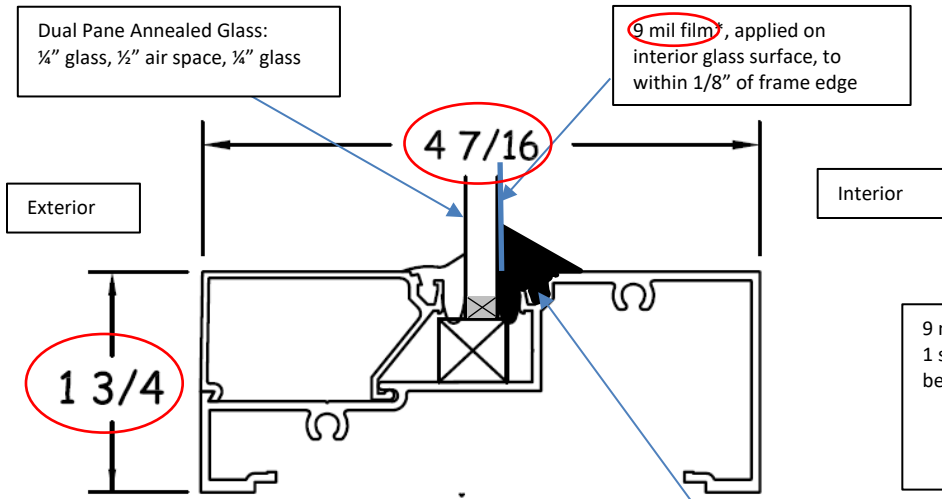

9 mil film*
1 set each of the following to be tested:
R20 SR PS9
DR15 SR PS9
DR25 SR PS9

SILL
DETAIL F9

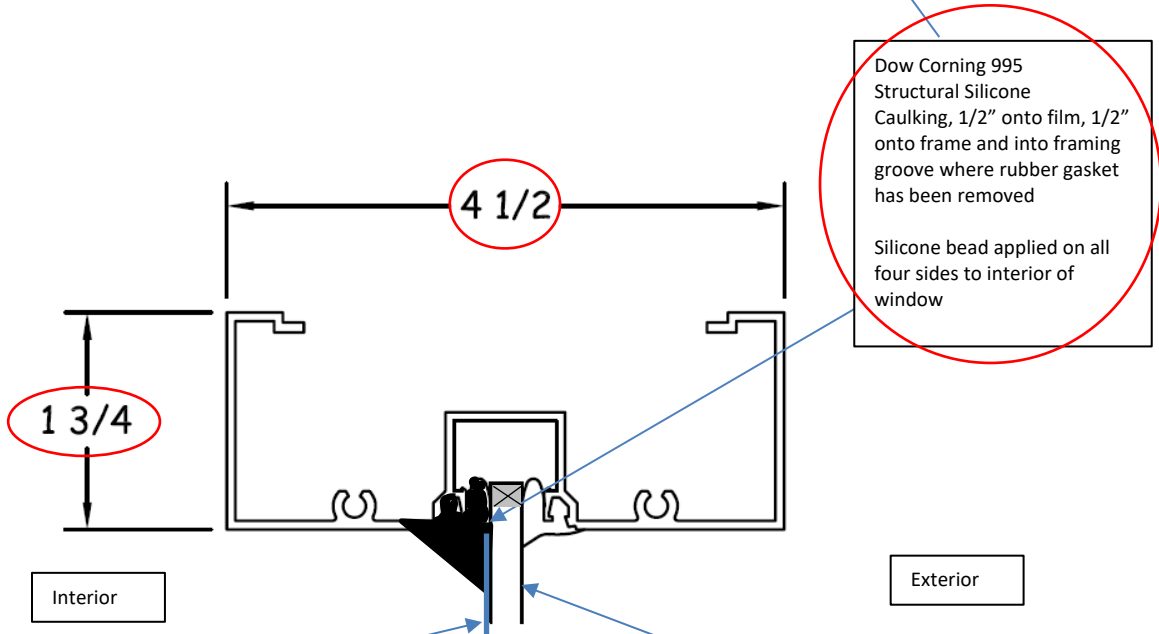

9 mil film*, applied on interior glass surface, to within 1/8" of frame edge

Dual Pane Annealed Glass

HEAD
DETAIL F12

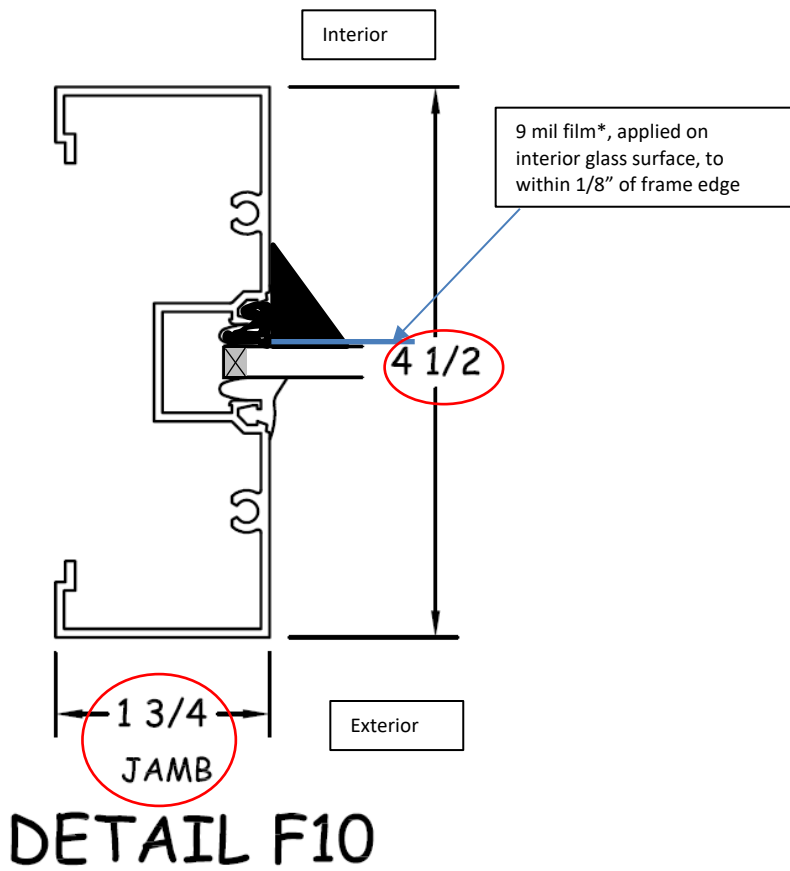



Total Quality. Assured.

130 Derry Court
York, Pennsylvania 17406

Telephone: 717-764-7700
Facsimile: 717-764-4129
www.intertek.com/building

TEST REPORT FOR EASTMAN PERFORMANCE FILMS, LLC

Report No.: J3550.01-109-44

Date: 06/28/19

SECTION 12

REVISION LOG

REVISION #	DATE	PAGES	REVISION
0	06/28/19	N/A	Original Report Issue